

Outer shell	: Brass (UNS C38500)	Chrome plated (FS-QQ-C-320B)
Earthing crown	: Brass (UNS C38500)	Nickel plated (FS-QQ-N-290A)
Collet nut	: Brass (UNS C38500)	Chrome plated (FS-QQ-C-320B)
Oversize collet sleeve	: Brass (UNS C38500)	Chrome plated (FS-QQ-C-320B)
Insulator	: PEEK	-
Male contact	: Brass (UNS C34500)	Gold plated (ISO 27874)
Clip	: Cu-Be (UNS C17200)	-
Gland	: Silicone (SI)	-
retaining ring	: Stainless steel (AISI304L)	-
Other metallic parts	: Brass (UNS C38500)	Nickel plated (FS-QQ-N-290A)
O-Rings	: Silicone (MVQ)	-
Male HV coaxial contact	: (FFS.2B.401.ZLCE34)	(See customer drawing)

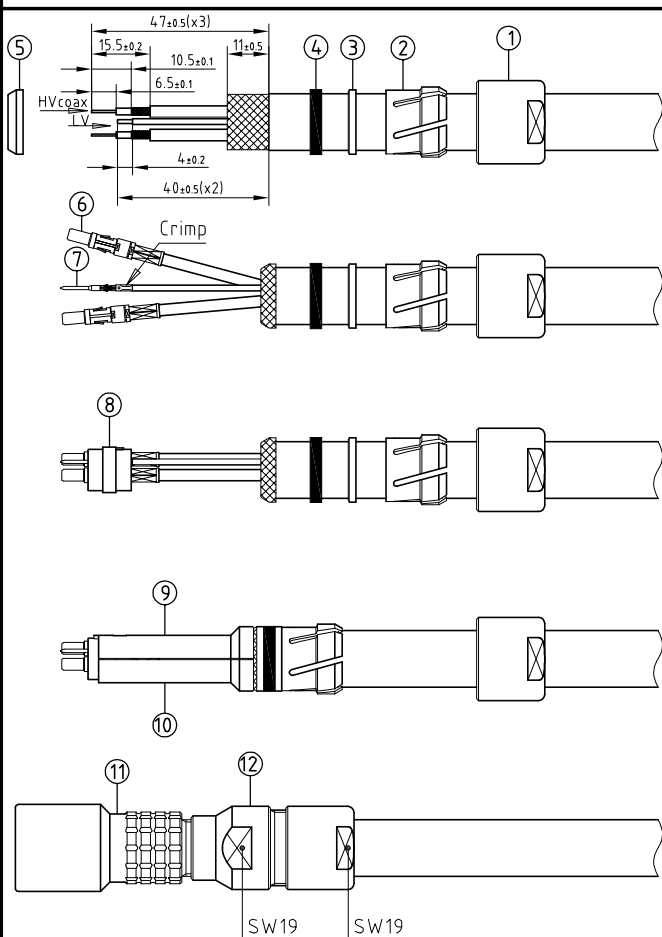

- Strip the cable according to the given dimensions . (The end of the cable jacket must be cut properly) . Slide it into the collet nut①, the collet②, the ring③, the gland④ and the earthing cone⑤.
- Mount the male coaxial contacts⑥ according to the separate instructions . In case of a screened cable , fold screen back over the extremity of the earthing cone . Fix the positioner on the crimping tool and set selector to the number corresponding to the conductor AWG as indicated on the positioner label . Fit conductor into the contacts⑦ and make sure it is visible through its inspection hole in the crimp barrel . Open crimping tool then push contact fully into positioner and complete one crimping cycle . Remove from crimping tool and check that conductor is secure in contact and shows in inspection hole .
- Slide contact-conductor combinations according to the insulator⑧ marking avoiding twisting of the conductors . Fit the contacts gently into the insulator and verify that no conductors are crossed before pushing them in completely . Check that all contacts hold in the insulator by verifying their alignment at the front of the insulator and they should remain in position when each conductor is given a gentle pull .
- Locate the slotted upper half⑨ of the split insert carrier over the shoulder and key on the insulator then align and press together the other half ⑩ to form a complete cylinder . Push the earthing cone against the insert carriers whilst checking that the screen is being clamped around the whole circumference and cut , if necessary , the excess screen . Push the gland , the ring and collet against the earthing cone . Push the cable forward and verify that cable jacket is located under the gland .
- Next slide the socket shell⑪ fitted with the oversize collet⑫ over the insulator assembly making sure that the key on the insert carrier goes into the keyway (under the color point) inside the shell . Ensure that the internal components do not rotate in the shell and finally screw the collet nut with the appropriate tool and tighten to the maximum torque value of 5Nm .

Crimping tool	: DPC.91.701.V	-
Extractor	: DCF.91.093.5LT	-
Male contact	: FGG.3B.560.ZZC	-
Male positioner	: DCE.91.093.BVC	-
Male retention testing tool	: DCK.91.091.4LRC	-

Straight socket , with keys (L) , with cable collet , oversize and nut .
Series 3K , 3HVcoax + 2LV(φ0.9)

ETUDE N° E1696-E7077-E2032-E3248

Echelle	Dessiné	16.05.2017	OVU / NHA
	Contrôle	16.05.2017	NHA / ATVI
	Modif.	00	16.05.2017/ OVU



LEMO

CH-1024 Ecublens

PHL.3K.7H2.CJCK__