

Outer shell	: Aluminium (AA 6262A) or (AA 6023)	Anthracite nickel
Earthing crown	: Cu-Be (UNS C17300)	Nickel plated (FS-QQ-N-290A)
Insulator	: PEEK	-
Grommet	: Fluorosilicone (FVMQ)	-
Female contact	: Bronze (UNS C54400)	Gold plated (ISO 27874)
Clip	: Cu-Be (UNS C17200)	-

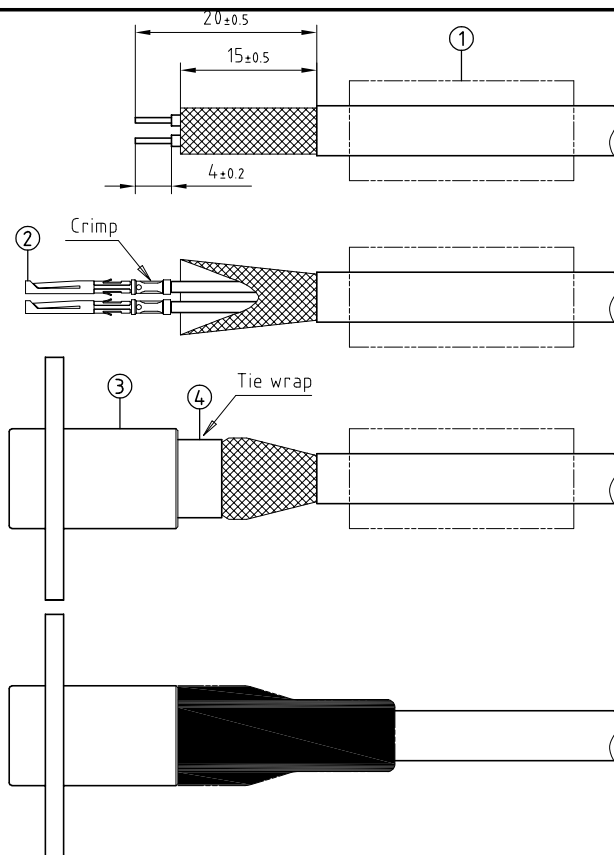

1. Strip the cable according to the given dimensions . Slide it into the heat shrink tubing①(not furnished) .
2. In case of a screened cable , widen and pull the screen all the way to the back . Fix the positioner on the crimping tool and set selector to the number corresponding to the conductor AWG as indicated on the positioner label . Fit conductor into the contacts②and make sure it is visible through its inspection hole in the crimp barrel . Open crimping tool then push contact fully into positioner and complete one crimping cycle . Remove from crimping tool and check that conductor is secure in contact and shows in inspection hole .
3. Slide crimped contact-conductor combinations according to the insulator marking by avoiding to twist the conductors . Introduce lightly the contacts into the insulator and verify that no conductors are crossed before pushing them completely . Check that all contacts hold in the insulator by verifying their alignment at the front of the insulator and they should remain in position when each conductor is given a gentle pull . Check that retention of the contact is correct with the recommended test tool . Bring the screen around the rear of the socket shell③and secure it with a band-it tie-wrap④(not furnished) to fix the screen in place . Cut , if necessary the excess screen .
4. Slide the heat shrink tubing . With a heat gun fully shrink the tubing until it retracts . Drill the panel hole and install the connector .

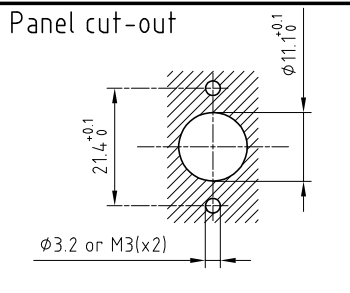

Crimping tool	: DPC.91.701.V
Extractor	: DCF.93.090.4LT
Female contact	: EGG.0B.661.ZZM
Female positioner	: DCE.91.090.BVM
Female retention testing tool	: DCK.91.091.4LRM

**Fixed socket with flange , with keys (N) ,
2 holes fixing .
Series 0F , multipole (3)**

ETUDE N° E2324-E7127

Echelle	Dessiné	11.07.2019	OVU / NHA
	Contrôle	11.07.2019	NHA / ATVI
	Modif.	00	11.07.2019 / OVU