

Outer shell	: Brass (UNS C38500)	Chrome plated (FS-QQ-C-320B)
Latch sleeve	: Special brass	Nickel plated (FS-QQ-N-290A)
Collet nut	: Brass (UNS C38500)	Chrome plated (FS-QQ-C-320B)
Cap	: Brass (UNS C38500)	Chrome plated (FS-QQ-C-320B)
Elbow outlet	: Brass (UNS C38500)	Chrome plated (FS-QQ-C-320B)
Insulator	: PEEK	-
Other metallic parts	: Brass (UNS C38500)	Nickel plated (FS-QQ-N-290A)

Male crimp contact	: To be ordered separately	See drawing FGG.0B.55_.ZZC
Collet	: To be ordered separately	See drawing FGG.0B.7_.DN

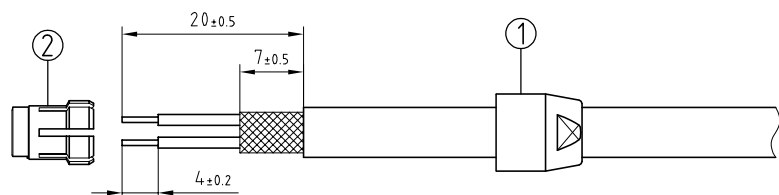

1. Strip the cable according to the given dimensions . Slide it into the collet nut ① and the collet ②.

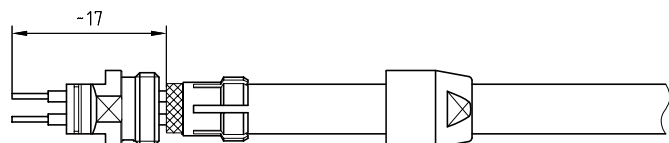

2. In case of a screened cable , fold screen back over the extremity of the collet according to the given dimension . Check that the screen which is folded back over the collet is clear of the slot . Slide the elbow outlet ③ onto the cable .

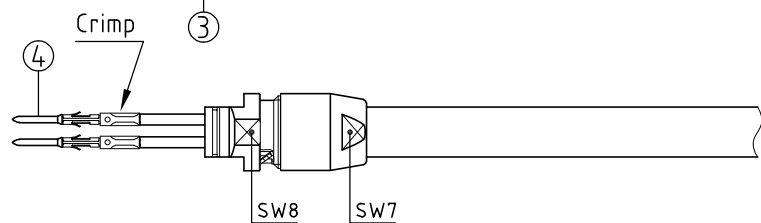

3. Place the inside key of elbow outlet with slot the collet whilst checking that the screen is being clamped around the whole circumference , and cut , if necessary , the excess screen . Screw the collet nut with appropriate tool and tighten to the maximum torque value of 0,5Nm . Fix the positioner on the crimping tool and set selector to the number corresponding to the conductor AWG as indicated on the positioner label . Fit conductor into the contacts ④ and make sure it is visible through its inspection hole in the crimp barrel . Open crimping tool then push contact fully into positioner and complete one crimping cycle . Remove from crimping tool and check that conductor is secure in contact and shows in inspection hole .

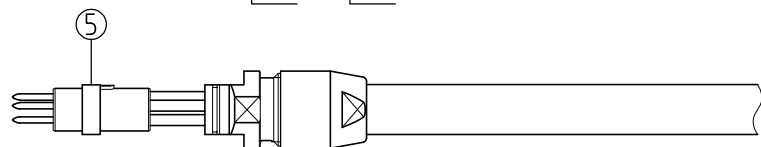

4. Slide contact-conductor combinations according to the insulator ⑤ marking , avoiding twisting of the conductors . Fit the contacts gently into the insulator and verify that no conductors are crossed before pushing them in completely . Check that all contacts hold in the insulator by verifying their alignment at the front of the insulator and they should remain in position when each conductor is given a gentle pull . Check that retention of the contact is correct with the recommended test tool .

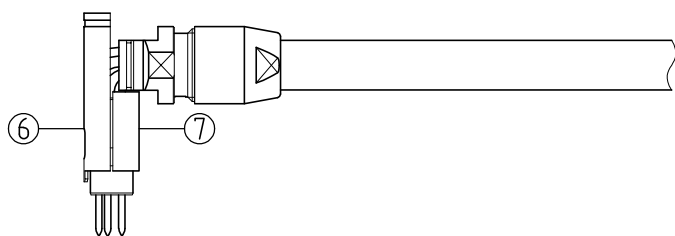

5. Locate the slotted upper half ⑥ of the split insert carrier over the shoulder and key on the insulator then align and press together the other half ⑦ to form a complete cylinder .

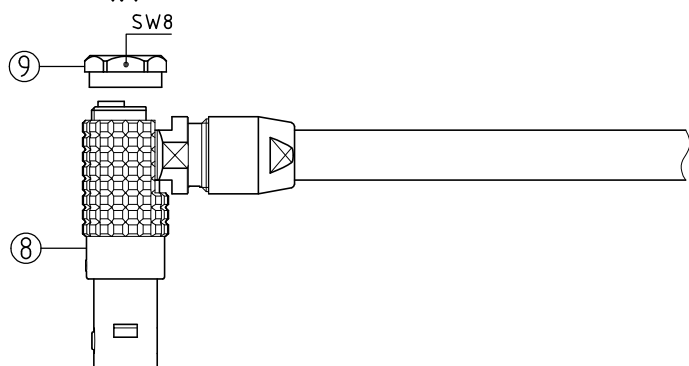

6. Push the insert assembly and slide the elbow outlet into the plug housing ⑧ making sure that the key on the insert carrier goes into the keyway (under the color point) inside the shell and finally screw the cap ⑨ with the appropriate tool and tighten to the maximum torque value of 0.6Nm .

Crimping tool	: DPC.91.701.V	Flat spanners set	: DCP.91.001.TN
Extractor	: DCF.92.070.3LT		
Male positioner	: DCE.91.070.BVC		
Male retention testing tool	: DCK.91.071.0LRC		

Elbow plug (90°), with key (G), without collet, with extended insulator for crimp contact. Series 0B, multipole (5) (without contacts)

ETUDE N° E10547

Echelle	Dessiné	27.06.2014	OVU / JPBA
	Contrôle	05.09.2018	NHA / ATVI
	Modif.	04	05.09.2018/ OVU



LEMO

LEMO SA
Chemin des Champs-Courbes 28
1024 Ecublens - SWITZERLAND

Tel. (+41 21) 695 16 00
email : info@lemo.com
www.lemo.com

FPG.0B.305.CYZZ