

Outer shell	: Brass (UNS C38500)	Chrome plated (FS-QQ-C-320B)
Retaining ring	: Brass (UNS C38500)	Chrome plated (FS-QQ-C-320B)
Insulators	: PTFE	-
Male contact	: Brass (UNS C38500)	Gold plated (ISO 27874)
Locking washer	: Bronze (UNS C52100)	Nickel plated (FS-QQ-N-290A)
Other metallic part	: Brass (UNS C38500)	Nickel plated (FS-QQ-N-290A)
Label	: Polyester	Yellow

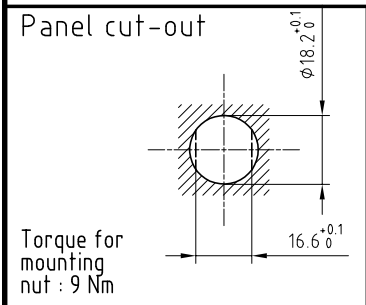
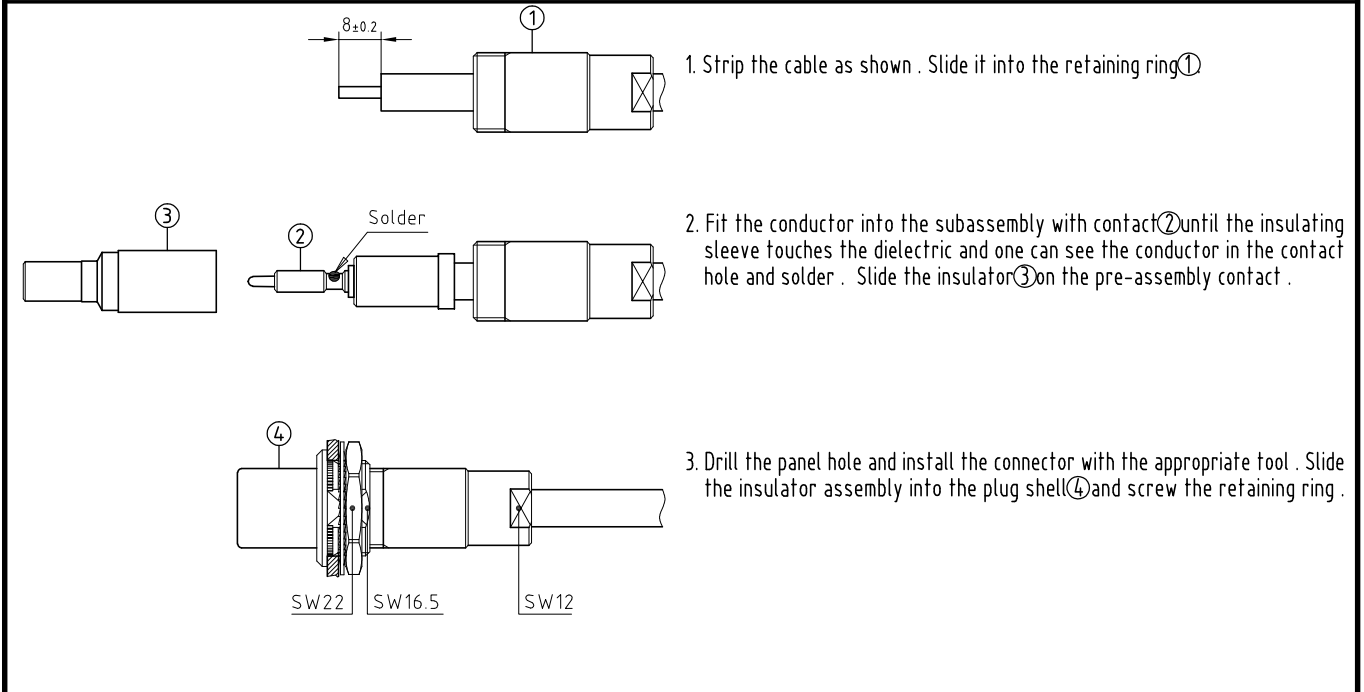

Spanner for nut	: DCA.91.282.2TN or
Spanner for nut	: DCG.91.282.2TN

**Straight plug , non-latching , nut fixing .  
Series 3S , (1) HV( $\phi 2$ )**

ETUDE N°

Echelle	Dessiné	20.05.2019	OVU / NHA
	Contrôle	20.05.2019	NHA / ATVI
	Modif.	00	20.05.2019/ OVU