

All dimensions are in millimeters (mm)

Alignment Key
Front View

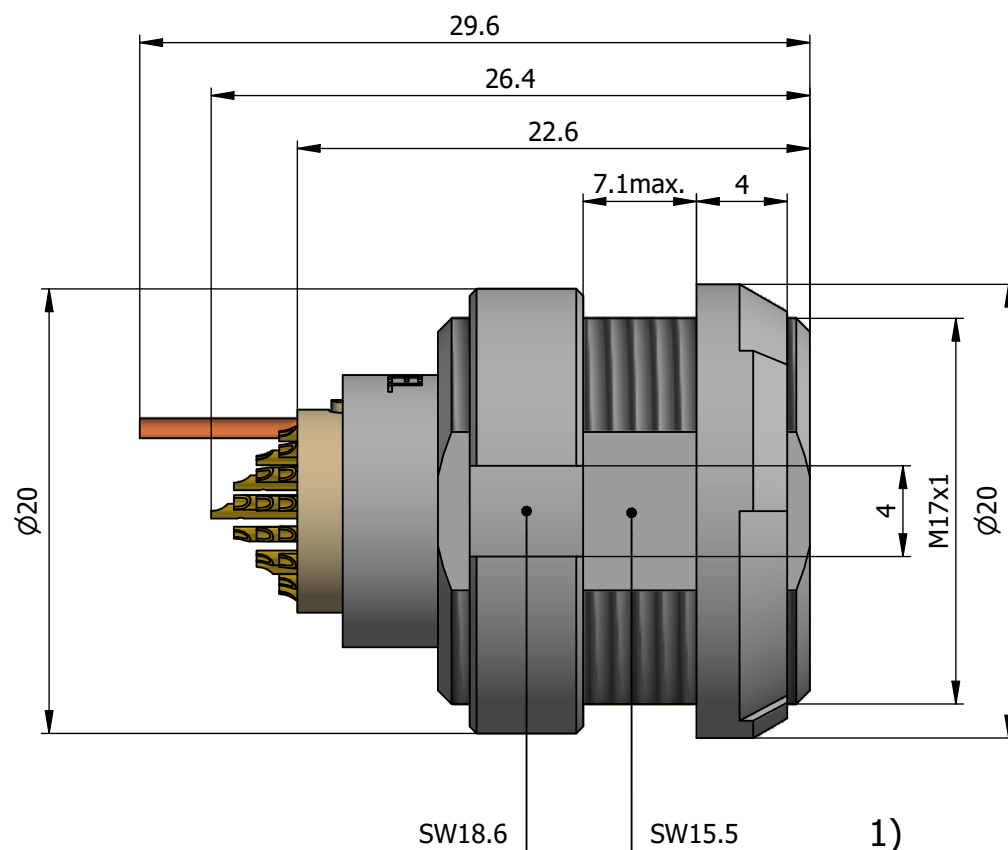

Insert Configuration
Rear View

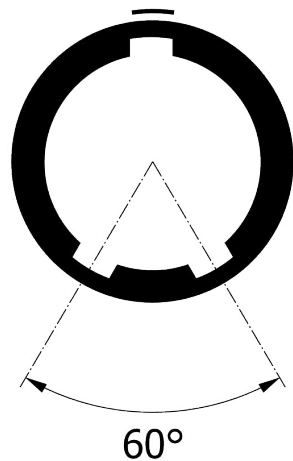
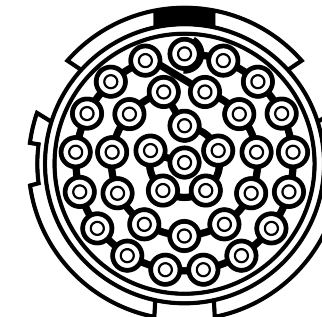

Recommended Panel Cut-Out

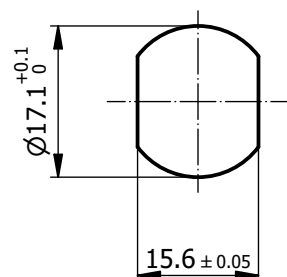

Mounting nut torque (Nm)
Plastic shell = 0.8

x Number of contacts

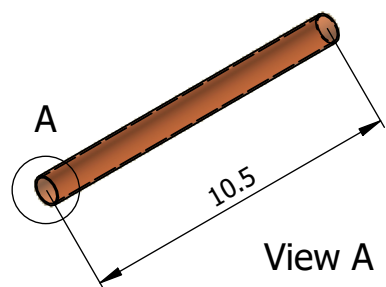

x 1



View A

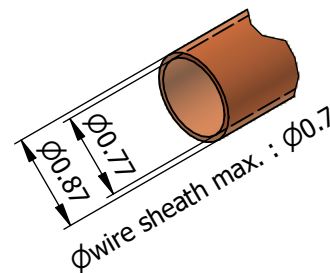

Note:

1) This picture is generic and for illustrative purposes only, and may show different keying, materials, colour, finish, and contact configuration. Minor shape or feature variations to actual item may be present.

All additional information are documented on the datasheet (See below link or QR Code)
www.lemo.com/pdf/CKB.H34.GLWG.pdf

Model Alignment Key
CKB.H34.GLWG

Insert Config.

Housing Insulator Contact Front Nut Color

Datasheet



Fixed socket with two nuts (back panel mounting), PFA HV Contacts
Series 2P



Redel SA
Rue du canal 2
1450 Ste-Croix - SWITZERLAND

Tel. (+41 24) 455 25 00
Fax. (+41 24) 455 25 01

CD

Drawn	27.05.2024	MARI / MARI
Checked	30.10.2024	OBAR
Modified	02	30.10.2024 / MARI
DO NOT SCALE DRAWING		

CKB.H34.GLWG